

Title: **MANUAL REPLACEMENT OF A  
ROTTEN / DAMAGED WOODEN  
POLE STRUCTURE**

Unique Identifier: **240-97759835**

Alternative Reference Number: **34-92**

Area of Applicability: **Engineering**

Documentation Type: **Task Manual**

Revision: **3**

Total Pages: **34**

Next Review Date: **November 2023**

Disclosure Classification: **Controlled  
Disclosure**

Compiled by

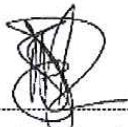

**Cyril Nuttall/David  
Ntombela**

**Senior Supervisor/Consult**

Date: 05/11/2018

Approved by



**Andre Bekker  
Middel Manager Design**

Date: 5 November 2018

Authorized by

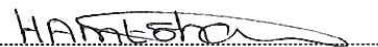

**Amelia Mtshali  
Senior Manager Power  
Delivery Engineering**

Date: 07/11/2018

Supported by SCOT/SC

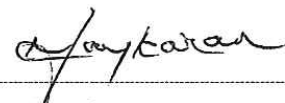

**Archie Jaykaran  
SCOT/SC Chairperson**

Date: 06 Nov 2018

## Content

	Page
1. Introduction .....	4
2. Supporting clauses .....	4
2.1 Scope .....	4
2.1.1 Purpose .....	4
2.1.2 Applicability .....	4
2.2 Normative/informative references .....	4
2.2.1 Normative .....	4
2.2.2 Informative References .....	5
2.2.3 Informative References .....	5
2.3 Definitions .....	5
2.3.1 General .....	5
2.3.2 Disclosure classification .....	6
2.4 Abbreviations .....	6
2.5 Roles and responsibilities .....	6
2.5.1 Plant Managers shall be responsible for: .....	6
2.5.2 Zone Manager shall be responsible for: .....	7
2.6 Process for monitoring .....	7
2.7 Related/supporting documents .....	7
3. Requirements .....	7
3.1 Pre-job Planning .....	7
3.1.1 Plant isolation .....	8
3.1.2 On-Site Risk Assessment .....	9
3.1.3 Safety and Preparation .....	9
3.2 Work execution .....	10
3.2.1 Damaged Wooden pole inspection .....	10
3.2.2 Scenario 1: .....	10
3.2.3 Scenario 2: .....	12
3.2.4 Scenario 3: .....	15
3.2.5 Scenario 4 .....	19
3.2.6 Scenario 5: .....	23
3.2.7 Scenario 6: .....	25
3.3 Energising plant .....	27
3.4 Task wrap up .....	27
3.5 Skill requirements .....	27
3.6 Related/Supporting Documents .....	27
3.6.1 Related Documents .....	27
3.6.2 Forms and Records .....	28
4. Authorization .....	28
5. Revisions .....	29
6. Development team .....	29
7. Acknowledgements .....	30
Annex A – Task Observation .....	31

**Figures**

Figure 1: Removing Tension from Damaged Suspension Pole .....15

Figure 2: Installing Replacement Suspension Pole .....16

Figure 3: Rotten / Damaged Suspension Pole Replacement.....18

Figure 4: Removing Tension from Damaged Strain Pole.....19

Figure 5: Installing Replacement Strain Pole .....20

Figure 6: Removing Tension from Damaged Strain Pole.....22

Figure 7: Damaged H Pole Strain Structure .....23

Figure 8: Installing Temporary H Pole Structures .....24

Figure 9: Planting H Pole Strain Structure Replacement Poles .....26

Figure 10: Stringed H Pole Strain Structures .....26

## **1. Introduction**

This task manual was compiled to conform or align with NRS 082, NRS 090, NRS 090-1-1 and OHSA requirements in ensuring that the equipment in Eskom Distribution network are maintained, the risks and hazards associated with task are minimized or mitigated.

This task manual was compiled from the analysis that was done on critical tasks that are being performed when maintaining network equipment in order to identify risks and hazards associated so that they could be addressed or remedied.

This document states the procedure for MANUAL Replacement of a Rotten / Damaged Wooden Pole Structure thereby ensuring that work is performed safely and risks and hazards are minimised.

## **2. Supporting clauses**

### **2.1 Scope**

#### **2.1.1 Purpose**

The purpose of this document is to provide persons performing MANUAL Replacement of a Rotten / Damaged Wooden Pole Structure with a step by step description of how to do the task, including the most critical hazards and technical specifications associated with the task.

#### **2.1.2 Applicability**

This Task manual is applicable to persons performing MANUAL Replacement of a Rotten / Damaged Wooden Pole Structure in Eskom Holdings (Pty) Limited, it's divisions or Eskom wholly owned subsidiaries.

## **2.2 Normative/informative references**

### **2.2.1 Normative**

- [1] ISO 9001, Quality Management Systems.
- [2] OHS Act, Occupation Health and Safety Act 85 of 1993 and Regulations;
- [3] 240-62196227, Life-saving rules
- [4] 240-114967625, Operating Regulations for High Voltage systems;
- [5] 240-120054284, Personal Protective Equipment Standard;
- [6] 240-86100853, Standard for Barricading Prohibited Area and Live Chamber;
- [7] 240-75883148, Specification For Conventional Stay Planting And Compaction, Pole Planting And Compaction And Rock Anchor Installation And Testing Standard;
- [8] DMN34-183, Backfill And Compacting Of Excavations;
- [9] 240-125124036, Standard For The Selection, Care, Use, Inspection And Maintenance Of Conductive And Non-Conductive Ladders;
- [10] 240-78692652, The Procedure for Use and Maintenance of Portable Earthing Gear;
- [11] 240-69125290, Standard for the Use of Equipontential Earth footplates;
- [12] 240-133791951, Maintenance inspection and supplemental treatment of treated wood utility Poles;
- [13] EPC\_32-418, Working AT Heights;
- [14] 240-82744167, Procedure For The Dismantling Of Medium & Low Voltage Power Lines On Wood Pole Structures
- [15] DISPVABI7, The Procedure for Manual Handling of Rural Line Poles;

**ESKOM COPYRIGHT PROTECTED**

- [16] D-DT-0330; LV and MV Reticulation pole foundation arrangement;
- [17] D-DT-0332; LV and MV Reticulation pole planting depth details;
- [18] Specific operating local instruction / procedure; and
- [19] Manufacturer's Manual

### 2.2.2 Informative References

- [20] DGL\_34-190, Access to Farms (includes Strategy on dealing with game farms);
- [21] 240-82744675, Procedure for refusal to work on the grounds of health, safety and environmental concerns;
- [22] DPC\_34-04, Procedure For The Preparation And Administration Of Distribution Standards;
- [23] DPC\_34-145, Assessment Procedure for HV Authorisation;
- [24] EPL\_32-727, Safety, Health Environmental & Quality (SHEQ) policy;
- [25] 240-70413713: Rev 0, Assessment Procedure for HV Authorisation;
- [26] EPC\_32-247: Rev 0, Procedure for Vegetation Clearance and Maintenance within Overhead Power Line Servitudes and on Eskom Owned Land; and
- [27] Manufacturers manual.

### 2.2.3 Informative References

## 2.3 Definitions

### 2.3.1 General

All definitions in 240-114967625, OHSAct 85 of 1993 and recognised industry glossaries such as NRS 000 and the IEV are applicable:

Definition	Description
<b>Authorised person</b>	means a person, whether an employee or another person, who has been authorised in terms of these regulations
<b>Responsible person</b>	means a person, who has been authorised to be responsible for ensuring that the work on the apparatus covered by work permit can be, carried out with safety and within the terms of these regulations
<b>Task Analysis</b>	The systematic examination of all dangerous/hazardous tasks (work) in order to identify and quantify all the potential and existing inherent hazards that employees are exposed to while the tasks are being executed.
<b>Risk Assessment</b>	This process involves the combined functions of hazards identification, risk analysis, risk evaluation, determining the risk control strategy/s and the identification of the risk control measures that will be implemented during the task execution.
<b>Dangerous/hazardous task</b>	A specific element of work, which has produced and/or which possesses the potential to produce major loss or harm to people, assets, processes/production and/or the environment when performed properly.
<b>Directive</b>	A document which sets out a management objective, the appropriate policy if deemed necessary, as well as the functional accountability for activities to achieve that objective and the interface between functions affected by, or responsible for the execution of, such activities.

Definition	Description
<b>Authorized</b>	A person who is trained and has been proven competent to carry out rotten pole replacement in terms of this standard. This authorization shall be in writing.
<b>Rotten Wooden Pole/unsound pole</b>	A pole that has been rejected after assessment and that shall be replaced. An unsound pole is a class 4 pole or a class 3 pole that will not be stubbed by the region (refer to 240-133791951 for classification of poles).
<b>Note:</b> Only persons who have satisfied the designated person on terms of the Occupational Health and Safety Act (Act 85 of 1993) (General Machinery Regulation 2(1)) that their knowledge is adequate to perform specific duties on specified plant and that their knowledge of these regulations is sufficient may be authorised.	

### 2.3.2 Disclosure classification

**Controlled disclosure:** controlled disclosure to external parties (either enforced by law, or discretionary).

## 2.4 Abbreviations

Abbreviation	Description
<b>CDP</b>	Career Development Programme
<b>CNC</b>	Customer Network Centre
<b>CO</b>	Construction Official
<b>GMR</b>	General Machinery Regulation
<b>ORHVS</b>	Operating regulations for high voltage systems
<b>OTS</b>	Officer Technical Support
<b>PCO</b>	Principal Construction Official
<b>PML</b>	Pedestal Mounted Ladder
<b>PPE</b>	Personal Protective Equipment
<b>PTO</b>	Principal Technical Officer
<b>SCO</b>	Senior Construction Official
<b>STO</b>	Senior Technical Officer
<b>TCIF</b>	Technology Change Information Forum
<b>TO</b>	Technical Officer
<b>PPM</b>	Power Plant Maintenance
<b>WCO</b>	Works-Coordinator

## 2.5 Roles and responsibilities

### 2.5.1 Plant Managers shall be responsible for:

- a) Ensuring that equipment job plans are available and issued for specific maintenance.
- b) Ensuring that the maintenance feedback information that is available in the maintenance management system is analysed.

**2.5.2 Zone Manager shall be responsible for:**

- a) Ensuring that staff carrying out maintenance tasks is trained, competent and authorized to perform maintenance on the specific equipment.
- b) Ensuring that instructions are implemented and adhered to and equipment is maintained in accordance to relevant work instructions.
- c) Ensuring that the maintenance feedback information / data is captured and recorded into the system for future maintenance planning.

**2.6 Process for monitoring**

Document number	Document title
240-45920887	Process Control Manual (PCM) for Manage Maintenance Base.
DPC_34-04	Procedure For Management Of Technical Documents For SCOT.

**2.7 Related/supporting documents**

Not applicable.

**3. Requirements**

**3.1 Pre-job Planning**

**Note 1:** If you lack knowledge of the area, environment, equipment, etc special care should be taken when performing the pre-task planning

- a) Do an assessment at the site to determine the scope of work and the resources that would be required (people, equipment, PPE, etc.) – also to determine the cause of loss, upgrade/down grade, cable fault etc
- b) All personal protective equipment shall be in accordance with 240-120054284.
- c) Plan work and resources required for the task
- d) Survey requirement.

**Note 2:** When survey is required the steps below shall be followed

- Where replacement structures are to be installed as discussed in the document it will be expected that Survey Department will profile and peg the new positions.
- Where strain structures are to be installed, all new stay positions will likewise be pegged.
- Survey will ensure the integrity of the line is not compromised and landowner rights are not infringed.

- e) Design.

**Note 3:** Where redesigning is necessary consult Design section.

- Design will ensure that the replacement structures will not compromise the integrity of the line.
- Design will supply a bill of materials and structural drawing references.
- The pole length of the pole replaced is to be the same as the pole that is removed and planted to the correct depth.
- The correct pole top diameter is to be used for the replaced pole.

**ESKOM COPYRIGHT PROTECTED**

- f) Information requirement.
- Receive task manual or contract document where applicable.
  - The supervisor / responsible person will interrogate the task manual or scope of work document and ensure all relevant information is contained in the document.
  - The supervisor / responsible person and appointed authorized operator will visit the site and conduct a formal Risk analysis.
- g) Tools and Equipment requirements.
- 3 x 2 sheave block
  - Suitable come-a-longs / conductor grips.
  - Long slings/tirfors of correct SWL
  - Ground anchors/dead-men/molex etc.
  - Pulling devices of correct SWL if needed to use with long slings.
  - Hand lines/tools etc.
  - Suitable transportation.
  - Pole prongs/Jin pole/a frame.
- h) Material requirements.
- Replacement wooden pole(s);
  - Replacement wooden cross-arm(s);
  - Replacement fitting bolts, back straps stay rods complete;
  - Replacement insulators/spindles/hardware/stay wire etc;
  - Conductor and mid-span joints; and
  - Wrap lock ties.
  - Armour-rods
- i) Tools and Equipment inspections.
- All tools and equipment to be used will comply with current OHSWA stipulations and Eskom requirement.
  - Equipment to be used must be inspected by a competent person prior to use and damaged equipment shall not be used but repaired, tested or discarded if they beyond repair.
  - Sub-standard equipment to be removed from service and locked away to prevent unauthorized use.

### **3.1.1 Plant isolation**

**Note 1:** Ensure that the supply has been isolated and earthed in accordance with procedure prior to performing tasks allocated.

**Note 2:** All work has to be executed under the supervision of a responsible person in terms of standards or procedures.

**Note 3:** All steps as identified in analysis of HV operating are applicable.

**Note 4:** Ensure that no tools, equipment and or material will fall and all steps as identified in the analysis of physical material handling are applicable.

**Note 5:** Ensure that live equipment are isolated and earthed in accordance with 240-114967625 (ORHVS) and HV operating task analysis / task manual.

**Note 6:** Ensure that the line has been handed over before commencing with work preparation.

**ESKOM COPYRIGHT PROTECTED**



- a) Ensure that the apparatus is opened, isolated and earthed, handed over (work permit) in accordance with 240-114967625

### **3.1.2 On-Site Risk Assessment**

- a) Conduct an on-site risk assessment prior to commencement of work and continuous during the task execution in accordance with EPC\_32-520.

**Note 1:** When doing an on-site risk assessment and executing the task the following hazards must be addressed:

**Note 2:** Do not take short cuts to save time

**Note 3:** Maintain and ensure that light / lighting is sufficient during task execution

**Note 4:** Lack of proper communicating ability – language, instructions, signals, etc

**Note 5:** Failure to correctly identify the critical existing hazards/risks

**Note 6:** Failure to minimise identified critical risks

**Note 7:** Not ensuring that appropriate PPE and safety equipment are identified, inspected and worn/used during execution of the task

**Note 8:** Not performing a proper risk assessment before task commencement or continuously during task execution in accordance with the prescribed procedure

**Note 9:** Tools, equipment and material falling to below may cause injuries and damage.

- b) Carry out tailgate / toolbox talk and sign the risk assessment forms before commencing with work.

### **3.1.3 Safety and Preparation**

**Note 1:** All steps as identified in analysis of HV Operating are applicable

**Note 2:** Maintain and ensure that light / lighting is sufficient during task execution

- a) Barricading shall be erected in accordance with 240-86100853 where necessary.
- b) Ensure that at no time will team members be permitted to ascend the rotten / damaged wooden pole in any manner whatsoever if not supported.
- c) At no time is the rotten / damaged wooden pole structure to be used as part of a lifting device.
- d) At all times the correct Personal Protective Equipment shall be used.
- e) Ensure that all tools and equipment to be used have been inspected by a competent person before they are used.
- f) The responsible person on site will continually supervise, direct and observe all activities.
- g) Work men to be reminded that they have “the right to refuse” if they consider the work is too dangerous or do not have the correct equipment or skills to safely complete the activity as per 240-82744675.
- h) Responsible and authorized person must ensure that the work site is prepared and made safe as per the 240-114967625 (ORHVS).
- i) Responsible person to sign the permit to work and complete workers register.
- j) On-site apply equipontential earthing in accordance with organisational standards and procedure (240-114967625 / ORHVS).

## 3.2 Work execution

### 3.2.1 Damaged Wooden pole inspection

- a) Inspect the damaged wooden pole in accordance to 240-133791951.

### 3.2.2 Scenario 1:

Damaged Suspension / Intermediate Pole Still Standing In Position – Able To Climb Against Pole with Ladder (When Pole Is Supported)

#### 3.2.2.1 Securing a damaged pole

**Note 1:** Ensure that plant has been isolated and earthed and handed over (works permit) where required in accordance with 240-114967625.

**Note 2:** Ensure that poor visibility due to insufficient light/lighting is addressed during the task execution.

**Note 3:** Work shall not commence without instruction been given by person supervising the task.

**Note 4:** Vehicles shall be adequately equipped (fire extinguisher, first aid box, tools and equipment, etc).

**Note 5:** Ensure material required to complete the task is available, adequate to complete task.

**Note 6:** Poor communication and inadequate supervision can result in injuries.

- a) Test the pole in accordance to 240-133791951 and stabilize the pole before placing any ladder by:
- Installing the anchor points on either side of the rotten / damaged pole for regulating, stabilizing and pulling ropes;
  - Attach two ropes either sides of the rotten / damaged pole;
  - Secure ropes using the operating stick at plus or minus two third of the pole length from ground level:\_ ensure that the safe working clearance is not encroached; and

**Note 6:** Ensure that the people pulling and controlling the ropes are at a distance twice the height of the pole.

**Note 7:** Ensure that pulling of the pole is done smoothly and no jerking should be allowed, this could lead to clashing of conductors at mid-span.

- Apply tension to the ropes to support the pole.

- b) Place the ladder against the pole and secure it.

#### 3.2.2.2 Disconnecting the conductors

**Note 1:** Not inspecting poles before positioning ladders may result in pole breaking off if rotten / damaged / vandalised.

**Note 2:** In the case of a T-off, check phasing visually before dismantling

**Note 3:** All steps as identified in the analysis of work with/on extension/single ladders are applicable

**Note 4:** Ensure that poor visibility due to insufficient light/lighting is addressed during the task execution

**Note 5:** Tools, equipment and material falling to below may cause injuries and damage

**Note 6:** Weight of conductor can cause injuries when handled – strains, pinching

- a) Place and secure the ladder in working position.
- b) Place the tools and equipment (snatch-block and rope) in the pouch.
- c) Climb the ladder to working position.
- d) Check and ensure that the cross arm and all hardware are sound and secured before removing the conductors and the pole.
- e) Attach the snatch-block to the structure.
- f) Remove binding from conductors.

**ESKOM COPYRIGHT PROTECTED**

- g) Control and lower the conductors.
- h) Descend to ground level.
- i) Remove the ladder from the pole.

### **3.2.2.3 Removing the damaged pole**

**Note 1:** Stub to be removed according to Regions requirements.

**Note 2:** Ensure that poor visibility due to insufficient light/lighting is addressed during the task execution.

**Note 3:** Knots in support ropes not hat are tied properly may loosen.

**Note 4:** Pole not lowered in a controlled manner may result in injuries and damage.

**Note 5:** Pole not removed from work site poses a serious tripping hazard.

- a) Secure base of the pole.
- b) Cut the pole off at ground level.
- c) Loosen the anchor ropes at the anchor point and support the pole manually (ie guide ropes etc.).
- d) Control and lower the pole to ground level (guide with the anchor ropes).
- e) Remove the pole from the work site (method of removal will depend on the specific situation).
- f) Refer to 240-82744167 for other methods that can be used for pole removal.
- g) Excavate the stump from the ground and backfill the hole.

### **3.2.2.4 Preparing the replacement pole**

**Note 1:** Knots in support ropes not that are tied properly may loosen

**Note 2:** Tools, equipment and material at work site can cause a tripping hazard

**Note 3:** Ensure that poor visibility due to insufficient light/lighting is addressed during the task execution

**Note 4:** Not using kick plate can cause soil to spill into hole and reduce the depth of the hole

- a) Drill the required holes.
- b) Treat the drilled holes.
- c) Fit the earth wire in accordance with the regional specifications
- d) Fit the label to the pole.

**Note 5:** Cross-arms can be fitted to pole before pole is planted

- e) Attach the cross arm to the pole where applicable.
- f) Attach the anchor ropes (four anchors).
- g) Position the kick plate in the hole
- h) Position the pole for planting (bottom of the pole shall rest against the kick plate).

### **3.2.2.5 Planting the replacement pole**

- a) Raise the pole to the vertical position using the anchor ropes for support.
- b) Position the pole in the centre of the hole and in line with the other poles.
- c) Ensure that the pole is plumb in the vertical position (use a plumb bob).
- d) Secure / hold the anchor ropes to keep the pole plumb.
- e) Remove the kick plate (where applicable) and backfill as per section below

**Note 1:** Ensure that poor visibility due to insufficient light/lighting is addressed during the task execution

**Note 2:** Pole not planted plumb and in line with other poles may cause strain on pole and insulators

**ESKOM COPYRIGHT PROTECTED**

### **3.2.2.6 Backfilling and compacting**

**Note 1:** Ensure that poor visibility due to insufficient light/lighting is addressed during the task execution.

**Note 2:** Incorrect backfilling or not in accordance with procedure may cause pole to topple / fall over.

**Note 3:** Not heaping the area around pole to 300mm can cause water to accumulate and cause pole to rot.

- a) Backfill the hole and compact the soil in layers.
- b) Heap the area / soil around pole to a height of  $\pm$  300mm above ground level and do not compact it the heaped soil

### **3.2.2.7 Dressing the pole top**

**Note 1:** Cross-arms can be fitted to pole before pole is planted

**Note 2:** Ensure phasing is correct with T-offs

**Note 3:** All steps as identified in the analysis of work with/on extension/single ladders are applicable

**Note 4:** Ensure that poor visibility due to insufficient light/lighting is addressed during the task execution

**Note 5:** Not using proper lifting techniques to lift and secure cross arm or conductors may cause injuries – straining, falling off ladder, cross arm falling on people below

**Note 6:** Tools, equipment and material falling to below may cause injuries and damage

- a) Secure the ladder in the working position.
- b) Place the tools and equipment (snatch block and rope) in the pouch.
- c) Climb the ladder to working position.
- d) If not previously completed follow the next steps:
  - Hoist the cross arm into position and secure.
  - Dress the cross arm and complete the earthing and bonding where applicable.
- e) Raise and secure the conductors.
- f) Remove the anchor ropes and equipment.
- g) Descend to ground level.
- h) Remove the ladder from the pole.

### **3.2.3 Scenario 2:**

The pole / structure is broken and lying on the ground with conductors still under tension/no tension: \_under Dead Conditions.

#### **3.2.3.1 Damaged / broken Pole Assessment**

- a) Ensure that plant has been isolated and earthed and handed over (works permit) where required in accordance with 240-114967625.

**Note 1:** Ensure that poor visibility due to insufficient light/lighting is addressed during the task execution.

**Note 2:** Work shall not commence without instruction been given by person supervising the task.

**Note 3:** Vehicles shall be adequately equipped (fire extinguisher, first aid box, tools and equipment, etc).

**Note 4:** Ensure material required to complete the task is available, adequate to complete task.

**Note 5:** Poor communication and inadequate supervision can result in injuries.

- b) Assess the conditions of damaged poles / structures.
- c) Inspect the poles / structures on either side of the broken structure to ensure that they are in good condition.

**ESKOM COPYRIGHT PROTECTED**

- d) Apply equipotential earthing at the work area as per 240-78692652
- e) Ensure that all accessible / encroaching metallic equipment ie. broken conductors are bonded to the same electrode as.

### **3.2.3.2 Disconnecting Conductors**

**Note 1:** In the case of a T-off, check phasing visually before dismantling

**Note 2:** All steps as identified in the analysis of work with/on extension/single ladders are applicable

**Note 3:** Ensure that poor visibility due to insufficient light/lighting is addressed during the task execution

**Note 4:** Tools, equipment and material falling to below may cause injuries and damage

**Note 5:** Weight of conductor can cause injuries when handled – strains, pinching

- a) Check and ensure that the cross arm and all other hardware are sound before removing the conductors and the pole.
- b) Check if the conductors are under tension or not, and when they are under tension, carry out the following steps to release tension:
  - Assess the weight of the conductors by referring from the conductor weight charts, where the conductor weight is manageable, use the nylon sling or the rope / s to attach the conductor to the temporary anchor.
  - Where conductor weight is considered heavy as determined from the weight chart, the conductors on either side of the damaged structure must be un-binded and lowered.
  - In turn tension the sling or control rope / s, remove the binding from conductor / s and slowly release the tension on the sling or control rope / s to free the conductor from the broken pole / s.

### **3.2.3.3 Damaged Pole Removal**

**Note 1:** Stub to be removed according to Regions requirements.

**Note 2:** Ensure that poor visibility due to insufficient light/lighting is addressed during the task execution.

**Note 3:** Knots in support ropes that are not secured properly may loosen.

**Note 4:** Pole not removed from work site poses a serious tripping hazard.

- a) Remove the broken pole / s from the work site (method of removal will depend on the specific situation).
- b) Where the pole stump is still in the ground, remove it.
- c) Refer to 240-82744167 for other methods that can be used for pole removal.
- d) Prepare the hole / s for the replacement pole / s, ensure that hole / s comply to the specifications.

### **3.2.3.4 Replacement Pole Preparation**

**Note 1:** Knots in support ropes that are not secured properly may be loosened

**Note 2:** Tools, equipment and material at work site can cause a tripping hazard

**Note 3:** Ensure that poor visibility due to insufficient light/lighting is addressed during the task execution

**Note 4:** Not using kick plate can cause soil to spill into hole and reduce the depth of the hole

- a) Where required drill the required holes on the pole and treat them accordingly.
- b) Fit the earth wire in accordance with the regional specifications.
- c) Fit the label to the pole.

**Note 5:** Cross-arms can be fitted to pole before it is planted

- d) Dress the pole / s as 3.4.3.7 below and attach the cross arm to the pole where applicable.

**ESKOM COPYRIGHT PROTECTED**

- e) Install anchors (four anchors) and attach anchor ropes.
- f) Position the kick plate in the hole
- g) Position the pole for planting (bottom of the pole shall rest against the kick plate).

#### **3.2.3.5 Planting Replacement Pole**

**Note 1:** Ensure that poor visibility due to insufficient light/lighting is addressed during the task execution

**Note 2:** Pole not planted plumb or in line with other poles may cause strain on pole and insulators

- a) Raise the pole to the vertical position using the anchor ropes for support.
- b) Position the pole in the centre of the hole and in line with the other poles.
- c) Ensure that the pole is plumb in the vertical position (use a plumb bob).
- d) Secure / hold the anchor ropes to keep the pole plumb.
- e) Remove the kick plate (where applicable) and backfill as per section below

#### **3.2.3.6 Backfilling and Compacting**

**Note 1:** Ensure that poor visibility due to insufficient light/lighting is addressed during the task execution.

**Note 2:** Incorrect backfilling or not in accordance with procedure may cause pole to topple / fall over.

**Note 3:** Not heaping the area around pole to 300mm can cause water to accumulate and cause pole to rot.

- a) Backfill the hole and compact the soil in layers
- b) Heap the area / soil around pole to a height of  $\pm$  300mm above ground level and do not compact the heaped soil

#### **3.2.3.7 Dressing the pole top**

**Note 1:** Cross-arms can be fitted to pole before pole is planted

**Note 2:** Ensure phasing is correct with T-offs

**Note 3:** All steps as identified in the analysis of work with/on extension/single ladders are applicable

**Note 4:** Ensure that poor visibility due to insufficient light/lighting is addressed during the task execution

**Note 5:** Not using proper lifting techniques to lift and secure cross arm or conductors may cause injuries – straining, or cross arm falling on people below

**Note 6:** Tools, equipment and material falling may cause injuries and damage

- a) Secure the ladder in the working position.
- b) Place the tools and equipment (snatch block and rope) in the pouch.
- c) Climb the ladder to working position.
- d) If the cross-arm was not previously installed follow the next steps:
  - Dress the cross arm and complete the earthing and bonding where applicable.
  - Hoist the cross arm into position and secure.
- e) Raise and secure the conductors.
- f) Remove the anchor ropes and equipment.
- g) Descend to ground level.
- h) Remove the ladder from the pole and wrap-up.

### 3.2.4 Scenario 3:

Damaged Suspension pole still standing in position – unable to climb against the pole with a ladder (pole may be partially burnt off, broken/rotten etc. (applicable to single and H poles).

#### 3.2.4.1 Preparation

**Note 1:** Maintain and ensure that light / lighting is sufficient during task execution

**Note 2:** Vehicles shall be adequately equipped (fire extinguisher, first aid box, tools and equipment, etc)

**Note 3:** Ensure material required to complete the task is available, adequate to complete task

**Note 4:** Ensure that equipment or material that are used, are correct, serviceable and up to standard

**Note 5:** Correct / repair any identified defects or replace substandard material

**Note 6:** Ensure the correct position and/or physical ability when digging / drilling

**Note 7:** If power tools are used incorrectly it can cause injuries to ears, eyes, wrists or lungs (inhalation of dust)

- a) Inspect wood poles adjacent to rotten / damaged pole to ensure that they are sound and can be climbed safely.
- b) If in doubt inspect and test the adjacent poles in accordance to 240-133791951 and stabilize the them before placing any ladder against them
- c) Ascend adjacent suspension poles and attach long slings / tiffors to conductors by means of the correct size and type of conductor grips / come-a-longs.
- d) Position the hoist or install ground anchors / dead men / molex's at mid spans.
- e) Attach long sling / tiffors to ground anchors / dead men / molex (see figure 1).

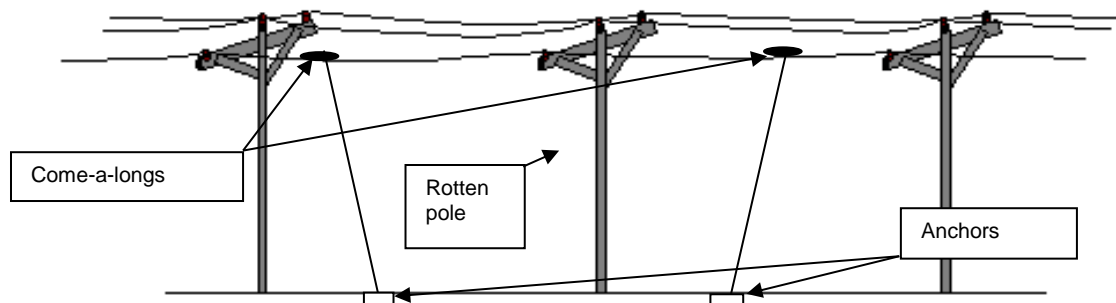

**Figure 1: Removing Tension from Damaged Suspension Pole**

**Note 8:** Ensure that centre phase to be evenly tensioned first, followed by simultaneous tensioning of the outer phases. Great care must be taken to ensure that tensions are evenly applied in relation to the rotten / damaged pole.

#### 3.2.4.2 Pole replacement

- a) Tighten long slings / tiffors both sides of the rotten / damaged pole sufficiently to reduce strain of conductors on rotten / damaged pole.

**Note 1:** All steps as identified in the analysis of physical material handling are applicable.

**Note 2:** Maintain and ensure that light / lighting is sufficient during task execution.

**Note 3:** Execute in accordance with standards and specifications.

**Note 4:** Knots in support ropes not sufficiently tied may loosen.

**Note 5:** Substandard equipment not to be used (support ropes, spikes).

**Note 6:** Tools, equipment and material at work site can cause a tripping hazard.

**Note 7:** Not using kick plate can cause the soil to spill into hole and reduce the depth of the hole.

**ESKOM COPYRIGHT PROTECTED**

**Note 8:** The depth of hole depends on the length of the pole.

**Note 9:** The existing pole hole can still be used where required.

- b) Excavate / drill the replacement pole position / hole as close as possible from rotten / damaged pole

**Note 10:** Where pole replacement is done manually, it is recommended that the hole be slotted to ease pole removal / erection (see figure 2).

- c) Dress the replacement pole and treat the drilled holes on the pole.  
d) Fit the earth wire onto the replacement poles in accordance to specifications where required.  
e) Partially assemble replacement pole, do not fit a cross arm at this stage as it could damage conductors during erection (see figure 2).

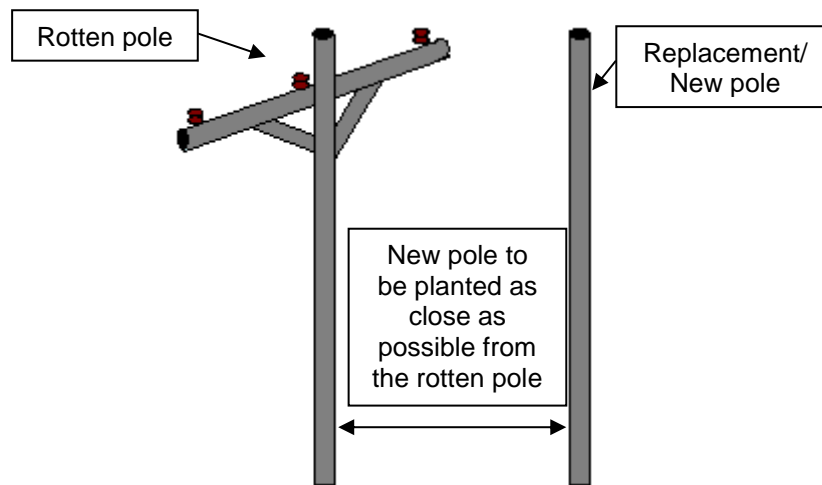

**Figure 2: Installing Replacement Suspension Pole**

**Note 11:** Please note that the soil around the replaced pole is to be compacted in 300mm layers using a hand compactor not weighing less than 10kg in weight.

**Note 12:** All steps as identified in analysis of physical material handling is applicable

**Note 13:** Maintain and ensure that light / lighting is sufficient during task execution

**Note 14:** Knots in support ropes not sufficiently tied may loosen

**Note 15:** Insufficient hands when raising pole can cause injuries – strains

**Note 16:** Ensure that no-one is standing in the line of fire (taking up unsafe position)

**Note 17:** Pole not planted plumb and inline with other poles may cause strain on pole and insulators

**Note 18:** Substandard equipment shall not be used (support ropes, spikes)

- f) Place the kick plate in position before raising the pole.  
g) Raise the pole to the vertical position using the anchor ropes for support.  
h) Position the pole in the centre of the hole and in alignment with existing poles.  
i) Ensure that the pole is plumb in the vertical position (plumb bob).  
j) Secure the anchor ropes.  
k) Remove the kick plate.

**Note 19:** Maintain and ensure that light / lighting is sufficient during task execution

**Note 20:** Incorrect backfilling, not in accordance with procedure may cause pole to topple

**Note 21:** Not back-filling area around pole can cause water to accumulate and can cause pole to rot

**ESKOM COPYRIGHT PROTECTED**



- l) Backfill the hole and compact the soil in layers.
- m) Backfill the area around the pole to a height of  $\pm 300$ mm above ground level.

**Note 22:** Ensure phasing is correct with T-offs.

**Note 23:** All steps as identified in the analysis of work with/on extension/single ladders are applicable

**Note 24:** Maintain and ensure that light / lighting is sufficient during task execution.

**Note 25:** Not using proper lifting technique to lift and secure cross arm or conductors may cause injuries – straining, falling off ladder, cross arm falling on people below.

**Note 26:** Tools, equipment and material falling to below may cause injuries and damage.

- n) Position and secure the ladder at the working position (against the replacement pole).
- o) Place the tools and equipment (snatch block and rope) in the pouch.

**Note 27:** Ensure FAS is used correctly.

- p) Climb the ladder to the working position.
- q) If not previously completed:
  - Hoist the cross arm into position and secure.
  - Complete the earthing and bonding where applicable.
- r) Raise and secure the conductors.
- s) Remove the anchor ropes and equipment from the replacement pole.

#### **3.2.4.3 Rotten / damaged pole removal**

**Note 1:** All steps as identified in the risk analysis of physical material handling are applicable.

**Note 2:** Pole not lowered in a controlled manner may result in injuries and damage.

**Note 3:** Knots of guide ropes not sufficient tied may loosen itself.

**Note 4:** Ensure that everybody is concentrating on their allocated task (person on guide rope, etc.).

**Note 5:** Ensure that no-one is standing in the line of fire (taking up unsafe position).

**Note 6:** Tools, equipment and material falling to below may cause injuries and damage.

**Note 7:** Ensure that workmen and the ladder are removed when old pole is lowered.

**Note 8:** Pole not removed from work site poses a serious tripping hazard.

- a) Secure rotten / damaged pole to snatch block by:
  - Attaching three and two sheaved / pulley block 2m below cross arm of the replacement structure (new pole) (see figure 3).
  - From the replacement pole attaching 3 x 2 block onto rotten / damaged pole 3m below cross arm.

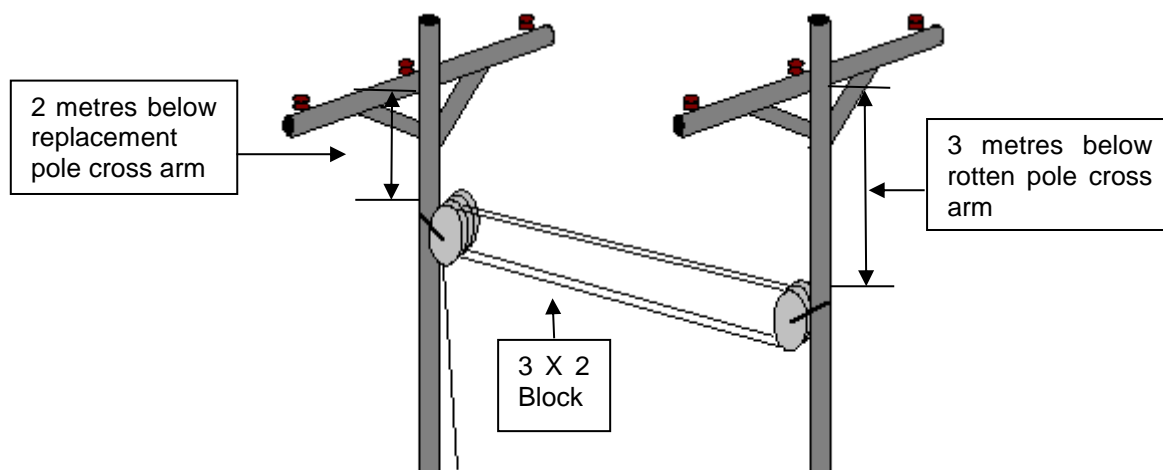

**Figure 3: Rotten / Damaged Suspension Pole Replacement**

- From the replacement pole (new pole) attach two guide ropes onto rotten / damaged pole.
- Ground staff to tighten the 3 x 2 block, and then fasten it to base of replacement pole (new pole) or through a pulley block, and attach to a ground-anchor.
- Guide ropes are to be held by staff or also attached to ground anchors.

**Note 9:** Not controlling conductor while handling can cause injuries

**Note 10:** Weight of conductor can cause injuries when handled – strains, pinching

**Note 11:** Damaged pole can become unstable when disconnected from conductors

**Note 12:** Tools, equipment and material falling to below may cause injuries and damage

- Working from the replacement pole (new pole) carefully remove conductors from rotten / damaged pole, slack off long slings/tirfors and clamp conductors onto replacement pole (new pole).
- Remove securing / guiding ropes from replaced pole.

b) Descend to ground level.

c) Remove the ladder from the newly planted pole.

d) When the damaged pole is removed complete without cutting it:

- Excavate rotten / damaged pole by forming a slotted hole where necessary: - the slot is to be dug opposite to the replacement pole (new pole).

**Note 13:** During this part of the activity at no time should any staff member be close to the rotten / damaged pole in case it breaks.

- When slotted excavation reaches the bottom of the rotten / damaged pole, attach guide ropes to stabilise the rotten / damaged pole.
- Lower the pole to ground by slackening off the 3 x 2 block and control or stabilise the pole as is being lowered to ground.
- Remove the rotten / damaged pole from the work site, back fill and compact the excavation.

e) When the damaged pole is removed by means of cutting:

- Attach the guiding ropes then cut the damaged pole off at ground level.
- Lower the pole to ground while guiding it.

**ESKOM COPYRIGHT PROTECTED**

- Excavate and remove the stump from the ground.
  - Remove the damaged pole and the stump from the work site (method of removing the pole will depend on the specific situation), back fill and compact the excavations.
- f) Remove all equipment and clean site.
- g) Responsible person / team leader to inform authorized operator that the work is complete and staff is removed from site, and sign the permit / workers register off.
- h) Post-mortem / de-briefing meeting to held with staff after the suspension rotten / damaged pole replacement activities is completed.

### 3.2.5 Scenario 4

Damaged strain pole structure still standing in position – unable to climb against pole with ladder (pole may be partially burnt off, broken/rotten etc.)

#### 3.2.5.1 Preparation

- a) Inspect wood poles adjacent to rotten / damaged pole to ensure that they are sound and can be climbed safely.
- b) If in doubt inspect and test the adjacent poles in accordance to 240-133791951 and stabilize the them before placing any ladder against them
- c) Ascend adjacent suspension poles and attach long slings / tirsors to conductors by means of the correct size and type of conductor grips / come-a-longs.
- d) Position the hoist or install ground anchors / dead men / molex's to be installed at the mid spans.
- e) Attach long sling // tirsors to ground anchors / dead men / molex (see figure 4).

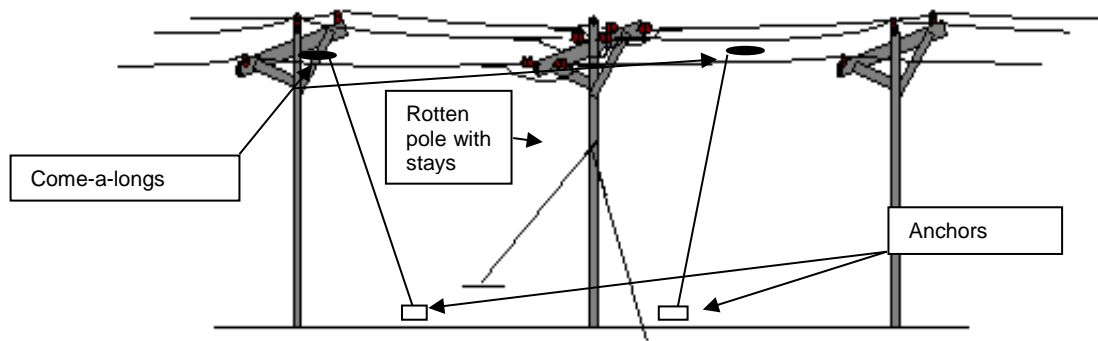

Figure 4: Removing Tension from Damaged Strain Pole

- f) Tighten long slings / tirsors both sides of the rotten / damaged pole sufficiently to reduce strain of conductors on rotten / damaged pole: - Centre phases to be evenly tensioned first, followed by the outer phases. Great care must be taken to ensure tensions are evenly applied in relation to the rotten / damaged pole.

#### 3.2.5.2 Pole replacement

**Note 1:** The existing pole hole can still be used where required.

- a) Excavate / drill replacement pole position / hole as close as possible from rotten / damaged pole on the inside of the angle or as per drawing number D-DT-0330 (see figure 5).

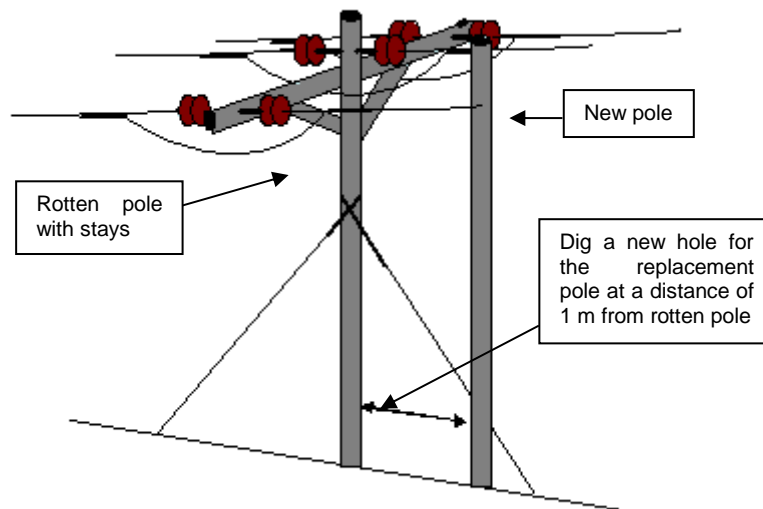

**Figure 5: Installing Replacement Strain Pole**

- b) Excavate stay holes for replacement structure and install stays.
- c) Ensure that the replacement pole excavation is slotted in manner that it will allow manual erection as per drawing D-DT-0332 (see figure 6).

**Note 2:** Please note that the soil around the replaced pole is to be compacted in 300 mm layers using a hand compactor not weighing less than 10kg in weight.

**Note 3:** Where pole replacement is done manually, it is recommended that the hole be slotted to ease pole removal / erection (see figure 2).

- d) Dress the replacement pole and treat the drilled holes on the pole.
- e) Fit the earth wire onto the new poles in accordance to specifications where required.
- f) Partially assemble replacement pole as per drawing (see figure 6).
- g) Place the kick plate in position before raising the pole.
- h) Raise the pole to the vertical position using the anchor ropes for support.
- i) Position the pole in the centre of the hole and in alignment with existing poles.
- j) Ensure that the pole is plumb in the vertical position (plumb bob).
- k) Secure the anchor ropes.
- l) Remove the kick plate

**Note 4:** Maintain and ensure that light / lighting is sufficient during task execution

**Note 5:** Incorrect backfilling, not in accordance with procedure may cause pole to topple

**Note 6:** Not back-filling area around pole can cause water to accumulate and can cause pole to rot

- m) Backfill the hole and compact the soil in layers
- n) Backfill the area around pole to a height of  $\pm 300$ mm above ground level.

**Note 7:** Ensure phasing is correct with T-offs.

**Note 8:** All steps as identified in the analysis of work with/on extension/single ladders are applicable

**Note 9:** Maintain and ensure that light / lighting is sufficient during task execution.

**Note 10:** Not using proper lifting technique to lift and secure cross arm or conductors may cause injuries – straining, falling off ladder, cross arm falling on people below.

**ESKOM COPYRIGHT PROTECTED**

**Note 11:** Tools, equipment and material falling to below may cause injuries and damage.

**Note 12:** Ensure FAS is used correctly.

- o) Place and secure the ladder into the working position
- p) Place the tools and equipment (snatch block and rope) in the pouch
- q) Climb the ladder to the working position
- r) If not previously completed follow the next steps:
  - Hoist the cross arm into position and secure.
  - Complete the earthing and bonding where applicable.
- s) Raise and secure the conductors.
- t) Tension and make-off stays, and ascend replacement pole.
- u) Attach conductor regulation equipment onto replacement pole, attach regulation equipment to conductors by use of come-a longs / conductor / wire grip etc (see figure 6).
- v) Evenly, tension conductors to initiate slack between replacement structure and rotten / damaged pole.
- w) Disconnect conductor from rotten / damaged pole, slack off long slings / tiffors and complete conductor regulation, clamp-in and finalize (see figure 6).
- x) Remove the anchor ropes and equipment from the replacement pole.

### **3.2.5.3 Rotten / damaged pole removal**

**Note 1:** All steps as identified in the risk analysis of physical material handling are applicable.

**Note 2:** Pole not lowered in a controlled manner may result in injuries and damage.

**Note 3:** Knots of guide ropes not sufficient tied may loosen itself.

**Note 4:** Ensure that everybody is concentrating on their allocated task (person on guide rope, etc.).

**Note 5:** Ensure that no-one is standing in the line of fire (taking up unsafe position).

**Note 6:** Tools, equipment and material falling to below may cause injuries and damage.

**Note 7:** Ensure that workmen and the ladder are removed when old pole is lowered.

**Note 8:** Pole not removed from work site poses a serious tripping hazard.

- a) Attach the 3x2 sheaved / pulley block on to rotten / damaged and replacement poles as per the next step:
  - Attach 3 sheaved block on to replacement pole 2m below lowest conductor attachment point (see figure 6).
  - Working from the replacement poles attach 2 sheaved block on to rotten / damaged pole 3m below lowest conductor attachment point (see figure 6).
  - The person on replacement pole to attach two guide ropes to rotten / damaged pole.
- b) Ground staff to tension the 3 x 2 block, then fasten to base of replacement pole or through a single pulley block attached to the base of replacement pole and attach to a ground anchor.
- c) Guide ropes are to be held by staff or can also be attached to ground anchors.
- d) When the damaged pole is removed complete without cutting it:
  - Excavate rotten / damaged pole by forming a slotted hole, the slot is to be opposite to the replacement pole.

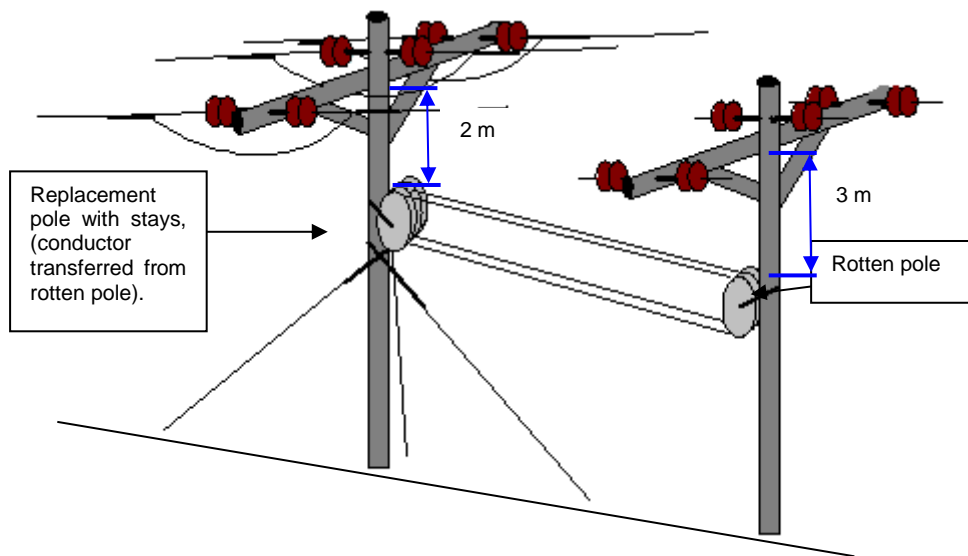

Figure 6: Removing Tension from Damaged Strain Pole

- e) When slotted excavation reaches the bottom of the rotten / damaged pole the guide ropes are to be used to stabilise the pole and the 3 x 2 block is to be slacked off to lower the rotten / damaged pole to the ground.
- Back fill and compact the rotten / damaged pole excavation;
  - Dismantle rotten / damaged pole; and
  - Remove the dismantled rotten pole from site.
- f) Descend to ground level.
- g) Remove the ladder from the newly planted pole.
- h) When the damaged poles are removed by means of cutting follow the next steps:
- Attach the guiding ropes then cut the damaged pole off at ground level
  - Lower the pole to ground while guiding it.
  - Remove the stump from the ground.
  - Remove the damaged pole from the work site (method of removing the pole will depend on the specific situation).
- Note 9:** During this part of the activity at no time should any staff member be standing close to the rotten / damaged pole in case it breaks.
- Remove securing / guiding ropes from rotten / damaged pole.
- i) When the damaged pole is removed, back-fill and compact the rotten / damaged pole and stay excavations.
- j) Dismantle conductor hardware from rotten / damaged pole, stays etc for removal from work site.
- k) Clean the work site and remove the staff.
- l) Inform authorized operator that the work is complete and all staff are removed from site and sign off permit.
- m) Post-mortem meeting is held with staff, and single strain rotten / damaged pole replacement activities are completed.

### 3.2.6 Scenario 5:

Damaged H pole strain structure where two sets of three single pole structures (triple poles) are erected as terminals and will be removed once rotten / damaged pole structure has been replaced

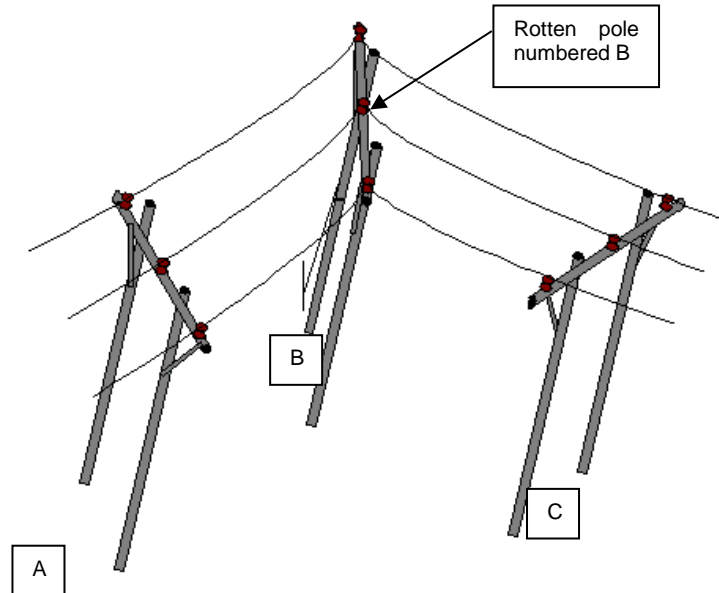

Figure 7: Damaged H Pole Strain Structure

**Note 1:** Depending on Design and Survey requirements the procedure described will entail the following two different scenarios.

#### 3.2.6.1 Preparation

- Inspect wood poles / structures adjacent to rotten / damaged pole / structure to ensure that they are sound and can be climbed safely.
- Excavate temporary poles position as pegged by survey, the holes must be slotted to allow for manual erection as per D-DT-0332.
- Excavate stay holes for temporary structures, install stays and assemble replacement poles per drawing.

**Note 1:** Please note that the soil around the replaced pole is to be compacted in 300 mm layers using a hand compactor not weighing less than 10 kg in weight.

- Manually erect temporary pole structures labelled number B and B1), plumb/square and compact poles, tension and make-off stays (see figure 8).

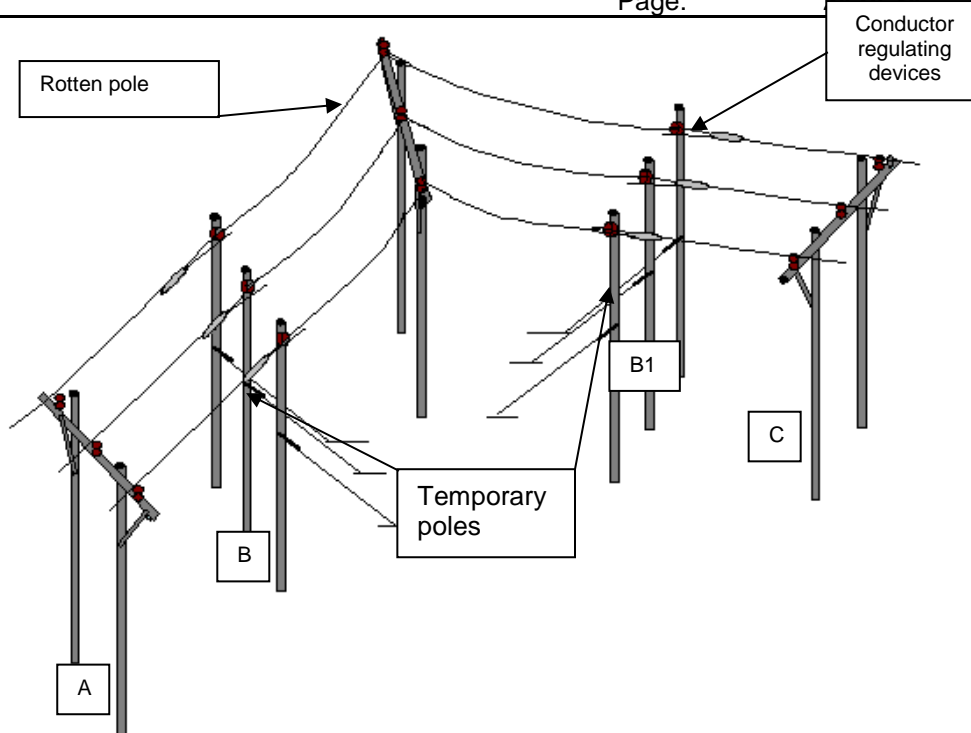

Figure 8: Installing Temporary H Pole Structures

- e) Ascend temporary structures and attach conductor regulation equipment to temporary poles.
- f) Evenly tension conductors to initiate slack between temporary structures and rotten / damaged pole (refer to figure 8).
- g) Cut conductors between temporary structures and rotten / damaged pole, maintain tension of long slings/tirfors.
- h) Complete conductor tensioning and clamp the conductors onto temporary structures.

### 3.2.6.2 Rotten / damaged pole / structure removal

- a) Use the hand-lines to hoist long slings and attach the slings on to cross arm ends of rotten / damaged poles.
- b) Attach the long slings to ground anchors and use the pulling device to tension.

**Note 1:** During this part of the activity at no time should any staff member be close to the rotten / damaged pole in case it breaks.

- c) Slacken the stays on the opposite side to long sling pulling direction, evenly tension the long slings and pull the rotten / damaged structure over.
- d) If structure legs have broken, ensure that the legs are free and released from the pole stumps still in the ground, lower / guide the pole structure with ropes until it is on the ground.
- e) Excavate stumps and remove, dismantle rotten / damaged pole, old conductor hardware, stays etc and remove from site.

**Note 2:** The existing pole hole can still be used where required.

### 3.2.6.3 Replacement pole / structure planting

- a) Assemble replacement strain-structure; erect it, plumb / square, backfill and tension stays of replacement strain structure.

ESKOM COPYRIGHT PROTECTED



- b) Run in the new conductors in between the replacement and temporary structures.
- c) Cut and join original conductor to new conductor ensuring the joint will not be closer than 30 meters from final attachment on new strain structure.
- d) Remove temporary poles and stays and attach conductors onto new strain structure.
- e) Disconnect and remove long bonds in reverse order.
- f) Tension, regulate and finalise conductors on new strain structure.
- g) Remove personnel, all equipment and clean the work site.
- h) Inform authorized operator that the work is complete and all staff is removed from site and sign the permit off.
- i) Post-mortem / de-briefing meeting is held with staff permit, workers register are signed off.

### **3.2.7 Scenario 6:**

Damaged H pole strain structure where two strain structures are erected as angle structures and will take the place of the replaced rotten / damaged pole structure. This will involve imposing a permanent extra structure into the line, which will require inclusion on the route plan

#### **3.2.7.1 Preparation**

- a) Inspect wood poles / structures adjacent to rotten / damaged pole / structure to ensure that they are sound and can be climbed safely.
- b) Ascend adjacent pole structures and attach long slings / tirsors to conductors by means of the correct size and type of conductor grips / come-a-longs.
- c) Excavate replacement structures holes as pegged by survey the holes must be slotted to allow for manual erection in accordance to D-DT-0332. (These structures will be so positioned to allow for angle deviation of conductors).
- d) Excavate stay holes for replacement structures, install stays and assemble replacement structure "legs" as per drawing.

**Note 1:** Cross arm is not to be attached at this time as it could damage the conductors and make the structure too heavy for safe manual erection.

**Note 2:** Please note that the soil around the replaced pole is to be compacted in 300 mm layers using a hand compactor not weighing less than 10 kg in weight.

#### **3.2.7.2 Replacement pole / structure planting**

- a) Manually erect replacement poles, plumb/square and compact poles (see figure 9).

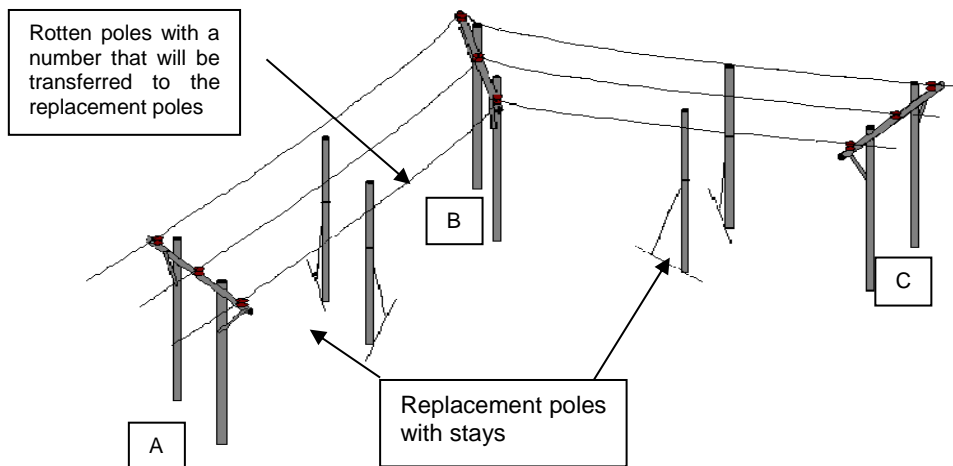

Figure 9: Planting H Pole Strain Structure Replacement Poles

- b) Tension and make-off stays, ascend replacement pole, use pulley blocks and hand lines, lift cross arm and attach it (see figure 10).
- c) Attach conductor regulation equipment to replacement structures cross arms.
- d) Evenly, tension conductors to initiate slack between replacement structure and rotten / damaged pole.
- e) Cut conductors between temporary structure and rotten / damaged pole, maintain tension of long slings/tirfors, complete conductor tensioning, regulate and clamp-in onto the replacement structures (see figure 10).

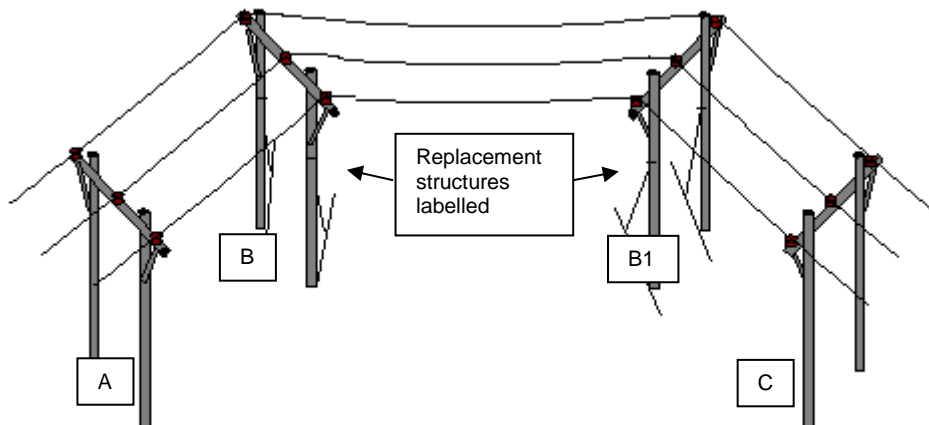

Figure 10: Stringed H Pole Strain Structures

- f) Disconnect and remove long bonds in reverse order.

### 3.2.7.3 Rotten / damaged pole / structure removal

- a) Use the hand-lines to hoist long slings and attach the slings on to cross arm ends of rotten / damaged poles.
- b) Attach the long slings to ground anchors and use the pulling device to tension.

**Note 1:** During this part of the activity at no time should any staff member be close to the rotten / damaged pole in case it breaks.

- c) Slacken the stays on opposite side to long sling pulling direction, evenly tension the long slings and pull the rotten / damaged structure over.
- d) If structure legs have broken, ensure that the legs are free and released from the pole stumps still in the ground, lower / guide the pole structure with ropes until it is on the ground..
- e) Excavate stumps, dismantle rotten / damaged pole, old conductor hardware, stays etc and remove from site.
- f) Back fill excavations and compact soil.
- g) Run conductors between the two new replacement structures, back hang conductors on one of the replacement structures, tension, regulate and finalise conductors on new strain structure.
- h) Affix new structure and line identification numbers, remove all equipment and clean site.
- i) Responsible person / Team Leader to inform authorized operator the work is complete and all staff is removed from work site, sign off the permit and workers register.
- j) Post-mortem / de-briefing meeting is held with staff, permit and risk assessment is signed off.

### **3.3 Energising plant**

**Note 1:** All steps as identified in the analysis of HV Operating are applicable

**Note 2:** Ensure supply is restored in accordance with ORHVS

**Note 3:** Maintain and ensure that light / lighting is sufficient during task execution

**Note 4:** Ensuring that all people, tools and equipment are removed prior to restoring supply

- a) Ensure that the plant is handed back (works permit) where required and re-energised in accordance with ORHVS
- b) Please take note of the following safety hazards:

### **3.4 Task wrap up**

**Note 1:** All steps as identified in the analysis of physical material handling are applicable.

**Note 2:** Ensure that data and risks are accurately recorded (history not recorded may prevent being able to trace person to job or alterations to plant).

**Note 3:** Ensure that recorded data is processed in accordance with requirements.

**Note 4:** Remove rotten/damaged pole from site – public can use as fire wood (toxic smoke due to creosote).

**Note 5:** Tools and equipment left at work place may result in time delays to recover when loss is discovered.

**Note 6:** Not disposing of redundant material in accordance with statutory and organisational requirements may result in damages/injuries to the environment/public/livestock and damage to the image of Eskom.

- a) Remove all personnel, equipment and redundant material from the work site
- b) Complete and submit the required documentation
- c) Please take note of the following safety hazards:

### **3.5 Skill requirements**

The skill level or craft required for executing the refurbishment tasks stated in this document shall be allocated in accordance to the relevant job plan.

### **3.6 Related/Supporting Documents**

#### **3.6.1 Related Documents**

- a) Standards, Procedures and Specifications;

**ESKOM COPYRIGHT PROTECTED**

- b) Critical task analysis; and
- c) Training module.

### 3.6.2 Forms and Records

The completed reports / forms must be returned to respective departments for record keeping:

- a) Works order
- b) Operating Instruction form / Workers register / Permit
- c) Risk Assessment
- d) In / Out commission sheet / Stores return

## 4. Authorization

This document has been seen and accepted by:

Name and surname	Designation
Amelia Mtshali	Senior Manager Power Delivery Engineering
Andre Bekker	Design Base Maintenance Manager
Archie Jaykaran	SCOT/SC Chairperson
Solly Matebula	Specialized and Maintenance Manager (GOU)
Reggie Moleko	Specialized and Maintenance Manager (FS OU)
Lumka Godlwana	Technical Support Manager (LOU)
Ian Mcfadden	Technical Support Manager (KZN OU)
Rodney Pretorius	Technical Support Manager (NW OU)
Nolan Ockhuis	Technical Support Manager (WC OU)
Ellie Mabaso	Technical Support Manager (NC OU)
Nomkhosi Zondo	Technical Support Manager (MOU)
Lindani Mbhele	Technical Support Manager (EC OU)
Cheryl Tanga	Technical Support Manager (FS OU)
Mphathutshedzeni Mudau	Technical Support Manager (G OU)

## 5. Revisions

This revision "240-97759835" supersedes and replaces all revisions of DMN\_34-92 and DISPVAEH0.

Date	Rev	Compiler	Remarks
Nov 2018	3	David Ntombela	Reviewed the Normative references Reviewed section "3.2.2.1 Securing a damaged" Included "If in doubt inspect and test the adjacent poles in accordance to 240-133791951 and stabilize the them before placing any ladder against them" in sections 3.2.4.1 & 3.2.5.1
May 2017	2	C Nuttall	Added Plant Isolation section Added scenario for replacing broken poles which are still attached to tensioned / un-tensioned conductors on the ground. Updated documents references
July 2015	1	C Nuttall	Register a 240 number for the document, reviewed and formatted into the new format. No content changed. The document is published as 240-97759835
March 2010	1	HCJ Nuttall	Document approved as DMN_34-92
			Included Foreword and revised the Introduction section
			2, Revised Normative and informative references
			3.5, Removed Implementation Date
			3.6, Removed Process for monitoring
			Reformatted the document
			Combined 34-92 rev 0 and dispvae0
Nov 2006	0	DM Ntombela	One document was original issues as DMN_34-92
Nov 2003	0	DM Ntombela	One document was original issues as DISPVAEH0

## 6. Development team

The following people were involved in the development of this document:

Name	Designation	Region
H J Martens	Officer Technical Support	WC OU
P van der Westhuizen	Senior Supervisor	EC OU
P Diedericks	SHE Manager	FS OU
S Delport	SHE Officer	MP OU
P Ramosili	Field Services Engineer	NW OU
M Lakhan	Officer Technical Support	KZN OU

**ESKOM COPYRIGHT PROTECTED**

Name	Designation	Region
D LeRoux	Officer Technical Support	WC OU
A Haynes	Senior Advisor	TX WP&CS
D Sadler	Middle Manager HV Plant	TX WP&CS
K Krafft	Senior Consultant	PDE-DBO
Pg De Jager	Officer Technical Training	HV Plant NE Grid
R Tee	Senior Engineering Assistant	TX South
F Van Jaarsveld	OTS	KZN OU

## 7. Acknowledgements

Not applicable.

**Annex A – Task Observation**  
(Normative)

	FORM TITLE	OBSERVATION FORM		
	FORM NUMBER	240-97759835	REV DATE	November 2023
	DOCUMENT TITLE	Replacement of a Rotten / Damaged Wooden Pole Structure		

1.	OBSERVER'S PARTICULARS							
	Task	observer's	name:	Task observed: Replacement of a Rotten / Damaged Wooden Pole Structure				
	Section	/	department:	Location:				
	Occupation:		Is there a procedure / task manual for this task?	YES	<input type="checkbox"/>	NO	<input type="checkbox"/>	
	Date:		Task Manual ref. ___	240-97759835				
	Time	with	task:	Work	order	no.:		
2.	REASON FOR OBSERVATION							
	Planned:	<input type="checkbox"/>	Follow-up:	<input type="checkbox"/>				
	Name of employee being observed:							
3.	TASK OBSERVATION							
	Did employee adhere to the procedure/practice requirements?							
		Yes	No	N/A		Yes	No	N/A
	Preplanning carried out correctly				5. Use of correct PPE			
	Emergency contacts numbers Obtained				6. Ensure that the panel / equipment to be commissioned is isolated and earthed in accordance with 240-114967625			

Tools equipment:				7. Carry out the task as per task manual (240-97759835)			
Used correctly							
In good and safe condition							
Test instrument calibrated							
Toolbox Talk:							
Task manuals used							
Complete Worker's register							
Risk Assessment been done							
Valid work permits available							
Could observed practices / conditions lead to:							
Injury:				Illness (fumes, gas, etc.)			
Risk of getting caught by				Costs (delays)			
Risk of striking against/get struck by				Poor quality (non-conformance)			
Risk of fall from same level							
Risk of fall from different level							
Risk of slip, trips and falls							
Risk of electrocution							
<b>4. NON COMPLIANCE PRACTICE OBSERVATION</b>							
	Yes	No	N/A		Yes	No	N/A
1. Working at unsafe speed				7.Failure to warn			
2. Using unsafe equipment				8. Taking chances			
3. Using equipment unsafely				9. Failure to identify hazards			
4. Unsafe loading, placing & lifting				10.Failure to secure lock-out			



	5. Taking unsafe position				11. Safety signs ignored			
	6. Safety rules ignored							
NOTE: ALL OBSERVED CLASS HAZARDS SHALL REQUIRE IMMEDIATE INTERVENTION								
5.	OBSERVED DEVIATIONS / NON-CONFORMANCES							
6.	RISK BEHAVIOURS							
7.	PROPOSED CONTROLS							
	Compile a procedure for this task				Issue a standing instruction			
	Revise present procedure				Change work methods			
	Retraining of employees				Professional referral			
	Engineering revision				Coaching			
8.	ANALYSIS							
	IAC – inadequate capability		ABU – abuse or misuse / equip / drugs or alcohol		MAIN – inadequate maintenance			
	KNO – lack of knowledge		NAT – natural factors		EQU – inadequate equipment			
	SKI – lack of skill		LEA – inadequate leadership		STA – inadequate work / train Standards			
	STR – stress		ENG – inadequate engineering		WEA – wear & tear			
	MOT – improper motivation		PUR – inadequate purchasing		CON – inadequate control			

9.	DISCUSSION BETWEEN SUPERVISOR/OBSERVER AND EMPLOYEE	
	1. EMPLOYEE EXPLANATION FOR RISK BEHAVIOUR:	
	2. AGREEMENT TO CHANGE AT RISK BEHAVIOUR:	
10.	FOLLOW-UP ACTIONS	WHEN / WHO

Person being Observed signature: \_\_\_\_\_ Date: \_\_\_\_\_

Signature (Task Observer): \_\_\_\_\_ Date: \_\_\_\_\_

Signature Chairperson Safety Committee: \_\_\_\_\_ Date: \_\_\_\_\_  
(if deviations were found)